

Car Lift 2000KG

IMPORTANT! PLEASE READ THESE INSTRUCTIONS CAREFULLY. NOTE ALL SAFETY INSTRUCTIONS AND WARNINGS. USE THE PRODUCT CORRECTLY AND WITH CARE FOR THE PURPOSE FOR WHICH IT IS INTENDED. FAILURE TO FOLLOW THESE INSTRUCTIONS MAY CAUSE DAMAGE TO PROPERTY AND/OR PERSONAL INJURY.

PLEASE KEEP THESE INSTRUCTIONS SAFE AND AVAILABLE FOR FUTURE REFERENCE.

SAFETY INSTRUCTIONS

Do not exceed the capacity indicated.

Once the load is lifted, it is imperative that the load is locked by means of the anti-tilt arm.

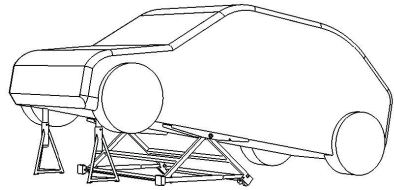
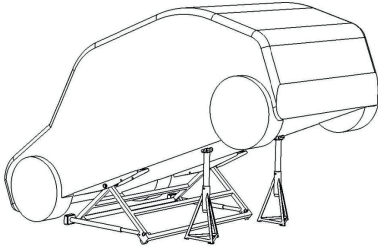

It is forbidden to work under the vehicle without having first positioned it on jack stands.

The anti-tilt arm gives additional safety, but does not remove the need to use jack stands.

Use a hard, level non-slippery surface, suitable for supporting the load.

Check that the load is stable on the lift. Make sure that there is no risk of it tilting or slipping.

Do not try to move the load when it is resting on the lift.

Do not use a damaged or worn lift.

Do not modify this item.

Do not drive onto this lift.

This lift is exclusively designed for lifting cars. Any other use is forbidden.

While lifting or lowering a car, do not allow anyone other than the operator to approach the vehicle.





If using a drill to raise and lower the car lift, follow the drill's instructions for use. Do not use where water is present.

When lifting or lowering, it is forbidden to keep the vehicle balanced on the car lift. You must let the vehicle rest freely on the front or rear wheels.

Not following these instructions may cause damage to property and people.

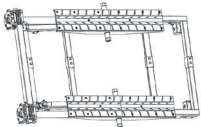
PARTS LIST

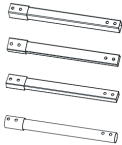
When unpacking this product, check to make sure the parts listed below are included and carefully inspect for any damage that may have occurred during transit. If any part is missing or damaged, do not attempt to assemble or use the product.

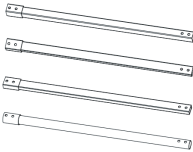
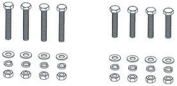
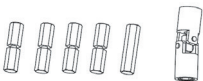
NO.	PICTURE	NAME	NO.	PICTURE	NAME
1		Car Lift	5		Transmission Shaft (Short/Long)
					Protective Cover (Short/Long)
2		Short Connecting Pieces	6		Crank Handle
3		Long Connecting Pieces	7		Bolts M8x55
					Nuts & Washers M8x40
4		Load Limiting Pins & Universal Joint			

ASSEMBLY INSTRUCTIONS

This car lift can be used in three configurations of different width settings (775mm/1130mm/1530mm), for use on different vehicles. Select the correct width for your vehicle and assemble accordingly following the instructions shown. The lift is supplied in 775mm width.

Disassembly

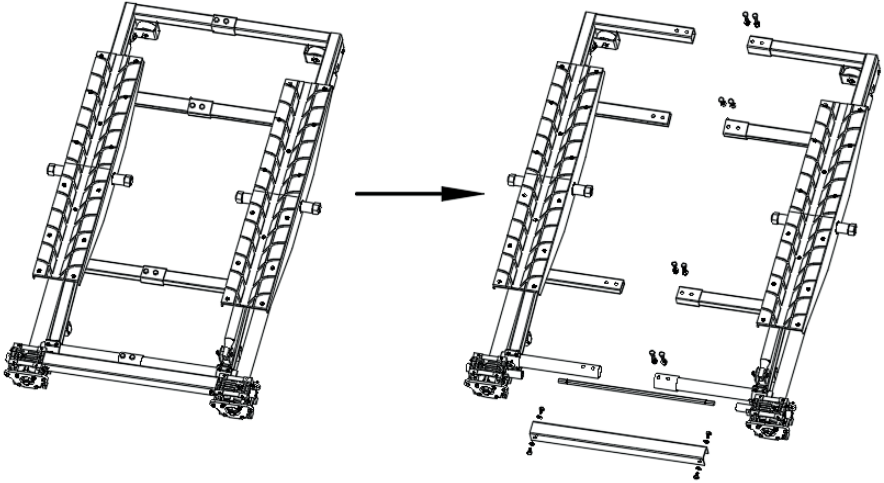

Remove the Bolts, Nuts, Washers, Protective Cover and Transmission Shaft as shown.

1130mm Assembly

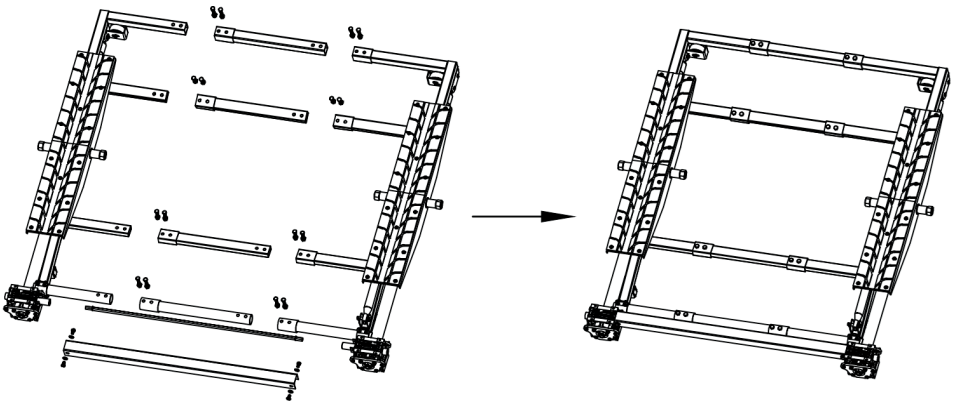

Arrange the Short Connecting Pieces (2), Short Protective Cover and Short Transmission Shaft (5) as shown. Tighten and assemble the car lift with Bolts, Nuts and Washers.

1530mm Assembly

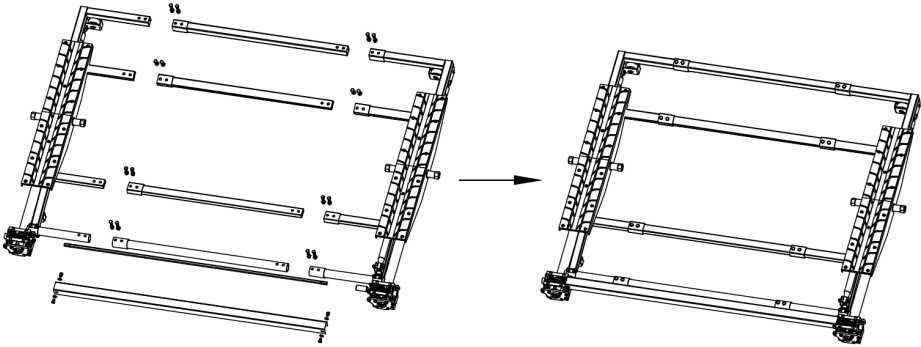

Arrange the Long Connecting Pieces 3, Long Protective Cover and Long Transmission Shaft 5 as shown. Tighten and assemble the car lift with Bolts, Nuts and Washers provided.

PRODUCT DESCRIPTION

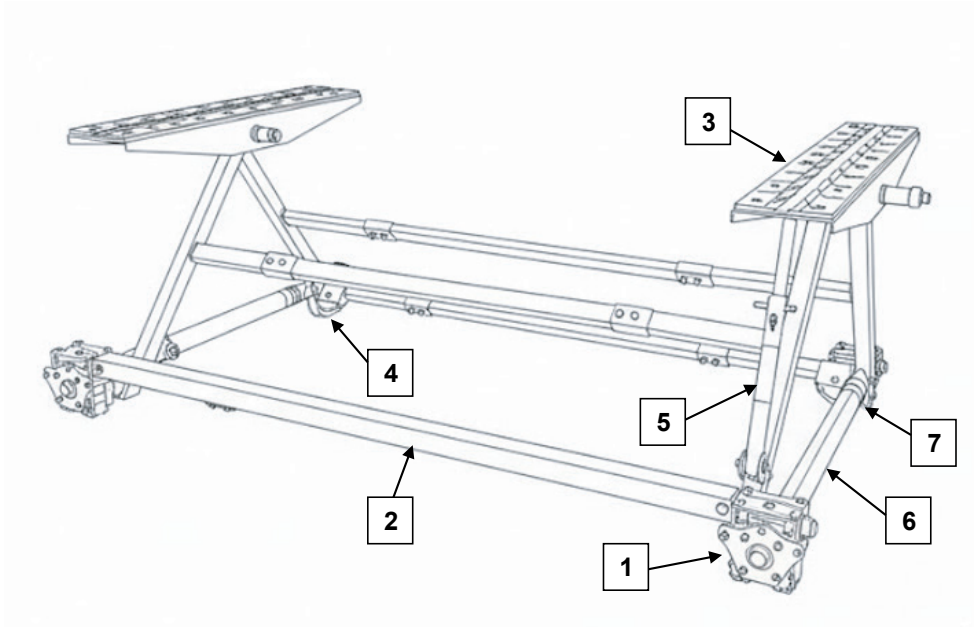

- (1) - Drive Housing
- (2) - Transmission Shaft
- (3) - Tilting Runners
- (4) - Castors
- (5) - Anti-tilt Safety Arm
- (6) - Threaded Rods
- (7) - Threaded Tube

SAFETY MEASURES

The Car Lift must be operated with an electric drill which has a sufficient torque (90 Nm). The use of impact wrenches, air bolt removers or striking tools is strictly forbidden because of the damage which could be caused to the drives.

Use on a flat, hard, smooth floor (for example, concrete). A rough floor can hinder the safe functional working of the Car Lift.

Before lifting or lowering the load, systematically check that the obstacles preventing the descent (jack stands and anti-tilt arm) are removed.

The warranty does not apply if the safety instructions and the safety measures are not followed.

Range of operating temperatures: -10 / +50 °C

SAFETY MEASURES

The connecting pin between the drill and the car lift acts as protection in the event of excessive load or when the maximum height is reached.

In these situations, the breaking of the pin is normal. Replace the pin with a new pin to continue using, making sure the instructions for maximum load and height are followed.

size of pin	capacity
6.0mm	1200-1300kg
6.5mm	1300-1400kg
7.0mm	1300-1400kg
8.0mm	1500-2000kg

The car lift is fitted with end stops, for the maximum lift and lowest positions. The load limiting pin will break if the user overrides the stops by continuing to operate the drill or handle.

Before approaching the maximum lift position, it is necessary to gradually slow the movement and stop the lift before reaching the stop. Never override the stops.

Do not use the car lift with different pins to those supplied with the car lift.

CAPACITY

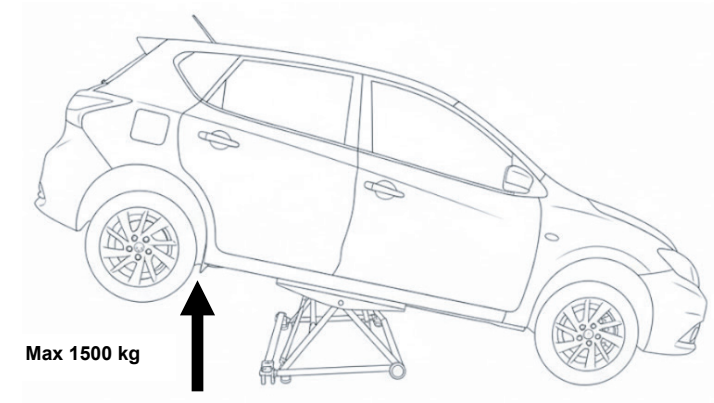

When lifting the vehicle, do not raise the 4 wheels simultaneously, let the vehicle rest on the front or rear wheels.

The maximum lifting capacity is 1500kg, you can lift heavier vehicles when 2 wheels are resting on the ground.

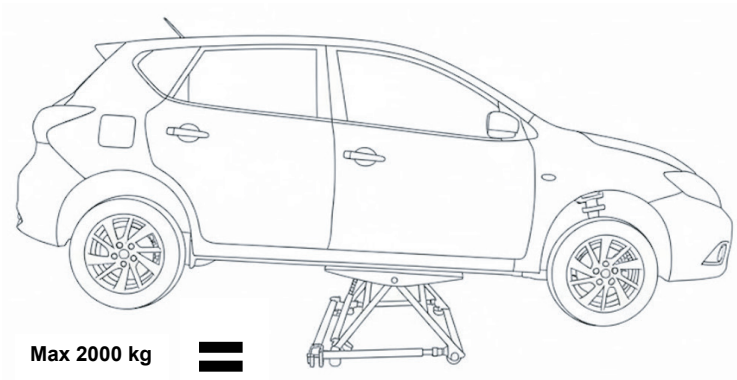

Once the vehicle is lifted, the maximum static capacity is 2000 kg. This means the vehicle can be placed horizontally with the four wheels lifted

UNPACKING

All the packaging (wooden case, protective blocks) must be disposed of in accordance with the environmental standards in force.

TRANSPORT

The Mini Lift is heavy. Do not try to lift it by yourself.

It is recommended that you take hold of it between the two drive housings and move it by rolling it on the castors located on the other side.

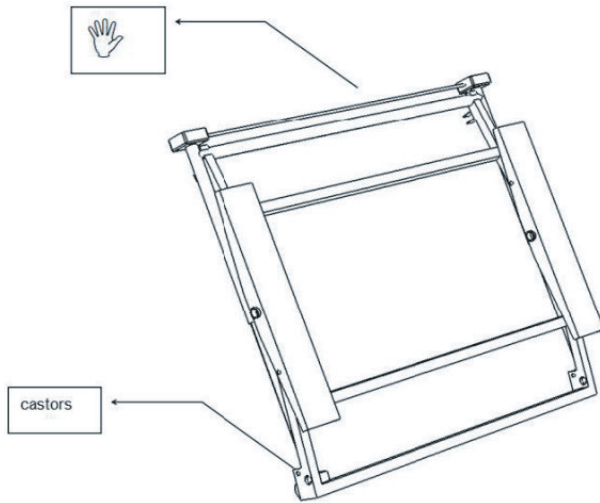

STORAGE

The Mini Lift must be stored on the housings or fixed to the wall on brackets (not supplied).

MAINTENANCE

Grease the drives in the drive housings and the moving parts at least four times a year or more often, in the case of intensive use.

To grease the drives, take out the 2 screws and open the covers of the housings.

To grease the threaded rods, open the filling cap located on the tubes.

INSTALLATION

-The vehicle must have the hand brake off and be in neutral. It must be on a horizontal surface so that it does not roll because of its own weight.

-Place the Mini Lift at the side of the vehicle. The drive housings must be placed towards the front of the vehicle.

-Slide the Mini Lift under the vehicle, until it is centred with the longitudinal axis of the vehicle. Adjust the distance between the runners to fit the width of the vehicle. The two rubberised runners must be symmetrical in relation to the bottom of the car body. Check that the runners are not in contact with any fragile component of the vehicle.

-To lift the front of the vehicle, place the drive housings in contact with the front wheels of the vehicle (for front-engine vehicles).

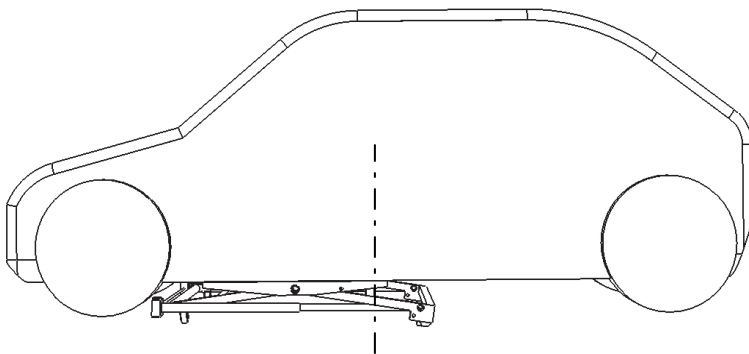

-To lift the rear of the vehicle, move the Mini Lift back slightly so that most of the weight is transferred onto the front wheels when lifted.

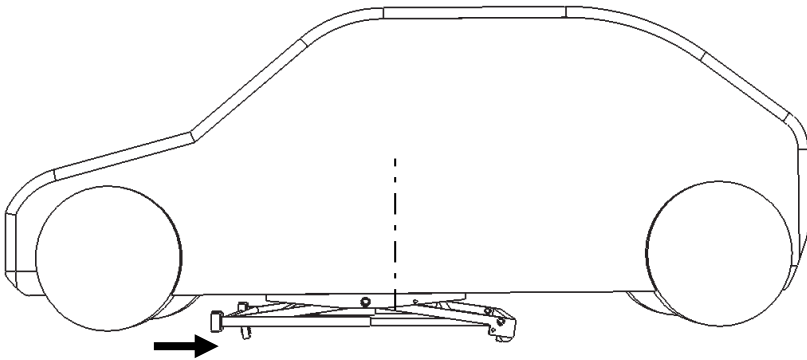

INSTALLATION

- If using the Crank Handle, use the Universal Joint supplied, the Crank Handle and the correct Load Limiting Pin turning in a clockwise direction.
- If using a drill, insert the Load Limiting Pin in the drill chuck.
- Operate the drill in a clockwise direction to lift, holding it firmly.
- Before reaching the maximum height, slow the lifting speed. Do not exceed the maximum height marked by the red line on the telescopic arm located on the side.
- Tighten the anti-tilt arm locking mechanism.
- Install the safety jack stands before working under the vehicle.
- Check that the vehicle is stable, before working underneath it. It must not be able to slip or tilt, even if the user should push against it while working. If there is a risk of the vehicle tilting, re-lower the Mini Lift and move it so as to place more weight on the wheels which remain on the ground.

LOWERING

- Loosen the anti-tilt arm locking mechanism. Failure to do so, will cause damage to the car lift.
- Operate the Car Lift using the drill (or the crank), changing the direction of rotation.
- Lower the Car Lift until the load is no longer resting on it and it can easily be removed from the side.
- Before reaching the minimum height, gradually slow the lowering speed.

LOWERING

Only for working on the front or the rear of the vehicle:

If the vehicle's centre of gravity is aligned with the axis of the Car Lift, it can tend to tilt either forward or back. To avoid this, it is imperative to use jack stands and the safety arm. In addition, it is recommended that the axis of the Car Lift is moved from the vehicle's axis of gravity, in order to place more load on the wheels that remain on the ground.

If one end of the vehicle is raised and the user wishes to work on the other end, you must lower it and then lift it again having changed the position of the Car Lift to change the distribution of the load and lift the desired end.

To lift the four wheels simultaneously:

The user must first lift either the front or the rear of the vehicle, once the desired height is reached, tilt the vehicle manually.

This operation must be done in the following way:

- Place two jack stands under the end of the vehicle which has been raised.
- One operator (or more) raises the vehicle to make it level and rest on the jack stands.
- Another operator comes and locks the anti-tilt arm and makes sure the vehicle is stable before the first operator releases the load.
- Place two further jack stands at the other end of the vehicle.

SAFETY NUT

The drive nut for the load can wear over time or if badly lubricated. In this case, a safety device holds the load, but it is no longer possible to lift or lower it.

Do not try to repair the Mini Lift so that you can continue to use it: only the manufacturer must be entrusted with the repair.

The operation of this nut can be checked via the inspection hole, situated on the tube (6). To do this:

-Lift the Mini Lift to approximately mid height.

-The threaded tube (7) has a hole which must be lined up with the inspection hole .

-If the nut is visible through the inspection hole, this is because it has been damaged. Stop using the Car Lift and send it to manufacturer for repair.

-The nut is in good operational order, if it is not visible through the inspection hole.



SGS Engineering (UK) Ltd
Unit 1 West Side Park
Raynesway
Derby, DE21 7AZ

EC Declaration of Conformity

This is an important document and should be retained

MANUFACTURER'S NAME: SGS Engineering (UK) Ltd
TYPE OF EQUIPMENT: Car Lift
PART NUMBER: SCL2000

APPLICATION OF EC COUNCIL DIRECTIVES / STANDARD:

Machinery Directive: 2006/42/EC
EN ISO 12100:2010
EN 1493:2010

I, the undersigned, hereby declare that the equipment specified above conforms to the above European Communities Directive(s) and Standard(s).

PLACE: Derby, UK

DATE: 01 May 2025

(Signature)

Neil Sansom
CEO

